

Seal Welded

Style BVS2				2
Carbon Steel Technical Data	2200 PSI	1/4" - 4"		3
316 Stainless Steel Technical Data	2160 PSI	1/4" - 4"		3
Style BVSC				4
Carbon Steel Technical Data	2200 PSI	1/4" - 2"		5
316 Stainless Steel Technical Data	2160 PSI	1/4" - 2"		5
Style BVS3				6
Carbon Steel Technical Data	3705 PSI	1/4" - 2"		7
316 Stainless Steel Technical Data	3600 PSI	1/4" - 2"		7
Style BVS6				8
Carbon Steel Technical Data	6170 PSI	1/4" - 2"		9
316 Stainless Steel Technical Data	6000 PSI	1/4" - 2"		9

3-Piece Maintenance Design

Style BVM3				10
Carbon Steel Technical Data	1973 PSI	1/4" - 2 1/2"		11
316 Stainless Steel Technical Data	1920 PSI	1/4" - 2 1/2"		11

Unibody

Style BVF1				12
Carbon Steel 150# Technical Data	285 PSI	1/2" - 1"		13
Carbon Steel 300# Technical Data	740 PSI	1/2" - 1"		13
316 Stainless Steel 150# Technical Data	275 PSI	1/2" - 1"		13
316 Stainless Steel 300# Technical Data	720 PSI	1/2" - 1"		13
Style BVF1				14
Carbon Steel 150# Technical Data	285 PSI	1 1/2" - 6"		15
Carbon Steel 300# Technical Data	740 PSI	1 1/2" - 6"		15
316 Stainless Steel 150# Technical Data	275 PSI	1 1/2" - 6"		15
316 Stainless Steel 300# Technical Data	720 PSI	1 1/2" - 6"		15

Split-Body

Style BVF2				16
Carbon Steel 150# Technical Data	285 PSI	1 1/2" - 8"		17
Carbon Steel 300# Technical Data	740 PSI	1 1/2" - 6"		17
316 Stainless Steel 150# Technical Data	275 PSI	1 1/2" - 8"		17
316 Stainless Steel 300# Technical Data	720 PSI	1 1/2" - 6"		17

Style BVS2

Ball Valve

Carbon Steel (ASTM A 216, Grade WCB)

Stainless Steel (ASTM A 351, Grade CF8M)

NPT Ends



Seal Welded High Pressure Ball Valve

APPLICATIONS

Industrial and Oil/Gas piping applications where the safety of seal welded construction is desired, the high flow capacity of full bore design is required, and operating pressures are 2160 PSIG or lower.

CONSTRUCTION

Keckley Style BVS2 seal welded high pressure ball valves are constructed from investment cast ASTM grade materials that are NACE MR0175 compliant. They are machined to exacting specifications. Full seal welding of body to tailpiece eliminates the possibility of the tailpiece unthreading, leaking or “blowing out” in service. All valves are shell and seat tested in accordance with API 598.

FEATURES

- Seal Welded Construction
- API 607 6th Edition Fire-Safe
- Full Port - All Sizes
- All Models are NACE MR0175 Compliant
- Elongated Packing Gland for Ease of Access When Automated
- Standard ISO Actuator Mounting Pads on All Sizes
- Standard Locking Stainless Steel Handles
- Electrically Grounded Ball and Stem
- Optional PEEK Seats for High Temp Services
- Optional Oval Handles

ORDERING

Reference *How to Order BVS2 Ball Valves* for building the Keckley Product Number.

WORKING PRESSURES - NON SHOCK

MATERIAL	MEDIA	¼" to 2"	8 mm to 50 mm
ASTM A 216, Grade WCB	W.O.G.	2220 PSI @ 100°F	15306 KPa @ 38°C
MATERIAL	MEDIA	¼" to 2"	8 mm to 50 mm
ASTM A 351, Grade CF8M	W.O.G.	2160 PSI @ 100°F	14893 KPa @ 38°C
MATERIAL	MEDIA	2-½" to 3"	65 mm to 80 mm
ASTM A 216, Grade WCB & ASTM A 351, Grade CF8M	W.O.G.	1500 PSI @ 100°F	10342 KPa @ 38°C
MATERIAL	MEDIA	4"	100 mm
ASTM A 216, Grade WCB & ASTM A 351, Grade CF8M	W.O.G.	1000 PSI @ 100°F	6895 KPa @ 38°C
MATERIAL	MEDIA	¼" to 4"	8 mm to 100 mm
ASTM A 216, Grade WCB & ASTM A 351, Grade CF8M	Saturated Steam (WSP)	200 PSI @ 388°F	1379 KPa @ 198°F

Note: Optional PEEK Seats WSP is 250 PSIG @ 406°F (1724 KPa @ 208°C)

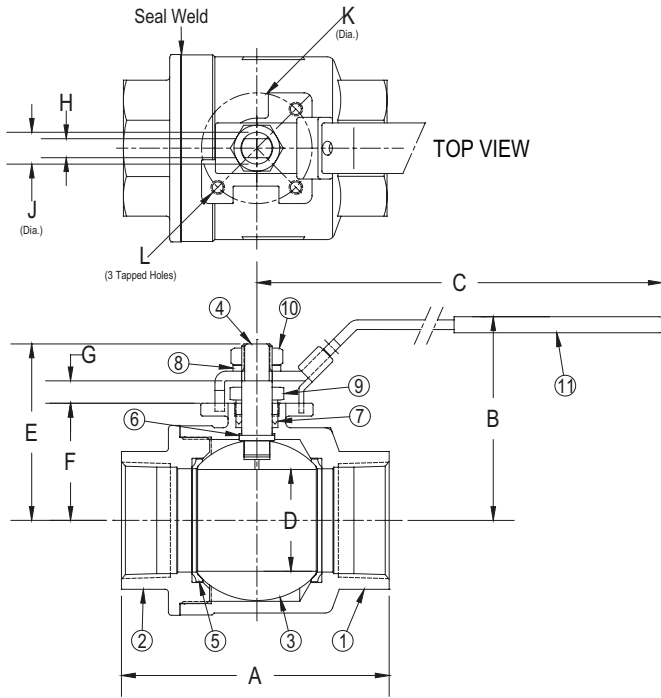

Style BVS2

Seal Welded High Pressure Ball Valve
NPT Ends

PARTS LIST			
ITEM	DESCRIPTION	MATERIAL	
1	Body	A 216 Gr. WCB	A 351 Gr. CF8M
2	Tailpiece	A 216 Gr. WCB	A 351 Gr. CF8M
3	Ball	A 276 Gr. 316	A 276 Gr. 316
4	Stem	A 276 Gr. 316	A 276 Gr. 316
5	Seat (2) [†]	R-PTFE	R-PTFE
6	Thrust Washer	R-PTFE	R-PTFE
7	Stem Packing	Graphite	Graphite
8	Spring Washer	304SS	304SS
9	Packing Gland	A 276 Gr. 316	A 276 Gr. 316
10	Lock Nut	304SS	304SS
11	Handle	300 Series SS	300 Series SS
	Pipe*	A 283, CS	A 283, CS
	Handle Bolt*	304SS	304SS
	Bolt*	304SS	304SS

*Parts referenced are for a 4" size only [Not Shown].
[†]Optional PEEK Seats for High Temp Service are available.

SIZE		DIMENSIONS														WEIGHTS	
in	mm	A		B		C		D		E		F		G		lbs	kgs
1/4	8	2.6	66.0	2.2	55.9	5.1	129.5	0.43	11.0	1.53	38.86	0.92	23.37	0.21	5.33	1.0	0.5
3/8	10	2.6	66.0	2.2	55.9	5.1	129.5	0.43	11.0	1.53	38.86	0.92	23.37	0.21	5.33	1.0	0.5
1/2	15	2.6	66.0	2.2	55.9	5.1	129.5	0.50	12.7	1.53	38.86	0.92	23.37	0.21	5.33	1.0	0.5
3/4	20	2.9	73.7	2.8	71.1	5.7	144.8	0.81	20.5	2.26	57.40	1.30	33.02	0.37	9.40	1.7	0.8
1	25	3.4	86.4	3.0	76.2	5.7	144.8	1.00	25.4	2.49	63.25	1.47	37.34	0.41	10.41	2.7	1.2
1-1/4	32	3.8	96.5	3.6	91.4	7.3	185.4	1.25	31.8	2.92	74.17	1.77	44.96	0.44	11.18	3.9	1.8
1-1/2	40	4.3	109.2	3.8	96.5	7.8	198.1	1.50	38.1	3.18	80.77	2.02	51.31	0.44	11.18	5.9	2.7
2	50	4.8	121.9	4.4	111.8	7.8	198.1	2.00	50.0	3.64	92.46	2.38	60.45	0.55	13.97	9.5	4.3
2-1/2	65	6.5	165.1	5.0	127.0	13.9	353.1	2.50	63.5	4.33	109.98	2.88	73.15	0.55	13.97	17.0	7.7
3	80	7.2	182.9	5.4	137.2	13.9	353.1	3.00	76.0	4.73	120.14	3.27	83.06	0.55	13.97	25.1	11.4
4	100	8.4	213.4	7.3	185.4	18.0	457.2	4.00	100.0	5.94	150.88	4.63	117.60	0.55	13.97	44.1	20.0

SIZE		DIMENSIONS								ISO PATTERN
in	mm	H		J		K		L		
1/4	8	0.20	5.08	0.31	7.87	1.42	36.0	1/4"-20 UNC		
3/8	10	0.20	5.08	0.31	7.87	1.42	36.0	1/4"-20 UNC		
1/2	15	0.20	5.08	0.31	7.87	1.42	36.0	1/4"-20 UNC		
3/4	20	0.28	7.11	0.44	11.18	1.65	42.0	1/4"-20 UNC		
1	25	0.28	7.11	0.44	11.18	1.65	42.0	1/4"-20 UNC		
1-1/4	32	0.35	8.89	0.56	14.22	1.97	50.0	1/4"-20 UNC		
1-1/2	40	0.35	8.89	0.56	14.22	1.97	50.0	1/4"-20 UNC		
2	50	0.35	8.89	0.56	14.22	1.97	50.0	1/4"-20 UNC		
2-1/2	65	0.47	11.94	0.75	19.05	2.76	70.0	5/16"-18 UNC		
3	80	0.47	11.94	0.75	19.05	2.76	70.0	5/16"-18 UNC		
4	100	0.67	17.02	1.03	26.16	2.76	70.0	5/16"-18 UNC		

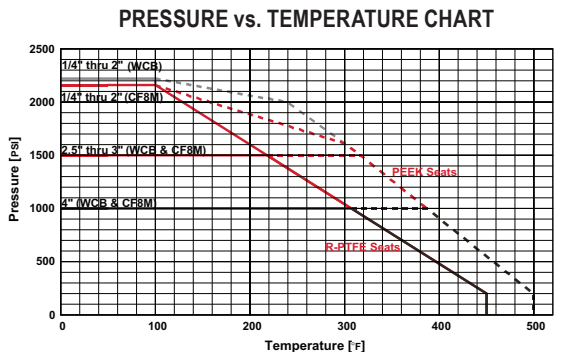

Certified dimensional drawings are available upon request.
[†]This table reflects only the nearest metric equivalents.

FLOW COEFFICIENTS

Size	C _v	Size	C _v	Size	C _v	Size	C _v
1/4"	10	3/4"	32	1-1/2"	140	3"	1100
3/8"	10	1"	62	2"	365	4"	2200
1/2"	18	1-1/4"	115	2-1/2"	450		

MAX TORQUE R-PTFE SEATS

Size	in/lb	Size	in/lb	Size	in/lb	Size	in/lb
1/4"	50	3/4"	120	1-1/2"	400	3"	1350
3/8"	50	1"	180	2"	600	4"	2200
1/2"	75	1-1/4"	300	2-1/2"	1050		

Style BVSC

Ball Valve

Carbon Steel (ASTM A 216, Grade WCB)

Stainless Steel (ASTM A 351, Grade CF8M)

NPT or Socket Weld Ends



Seal Welded High Pressure Ball Valve ASME B16.34 Class 900

APPLICATIONS

Industrial and Oil/Gas applications where ASME B16.34 and/or API 608 Class 900 construction are required, especially in piping systems that must be compliant with the ASME B31 Piping Codes. Also, in any application requiring API 607 6th Edition Fire Safe certification or NACE compliance.

CONSTRUCTION

Keckley Style BVSC seal welded ball valves are full ported and constructed in either CF8M or WCB body materials, both with 316ss ball and stem. They benefit from heavier ASME compliant wall thickness in body and tailpiece, and carry full ASME Class 900 pressure ratings. The handle-ball-stem drivetrain complies with API 608 strength and safety factor requirements, as do bore diameters, seat ratings, and electrical grounding of ball and stem.

FEATURES

- Seal Welded Construction
- Fully Compliant to ASME B16.34 Class 900
- Fully Compliant to API 608
- API 607 6th Edition Fire-Safe
- Full Port - All Sizes
- All Models are NACE MR0175 Compliant
- Elongated Packing Gland for Ease of Access When Automated
- Standard ISO Actuator Mounting Pads on All Sizes
- Standard Locking Stainless Steel Handles
- Electrically Grounded Ball and Stem
- Optional PEEK Seats for High Temp Services
- Optional Oval Handles

ORDERING

Reference *How to Order BVSC Ball Valves* for building the Keckley Product Number.

WORKING PRESSURES - NON SHOCK

MATERIAL	MEDIA	¼" to 2"	8 mm to 50 mm
ASTM A 216, Grade WCB	W.O.G.	2220 PSI @ 100°F	15306 KPa @ 38°C
MATERIAL	MEDIA	¼" to 2"	8 mm to 50 mm
ASTM A 351, Grade CF8M	W.O.G.	2160 PSI @ 100°F	14893 KPa @ 38°C

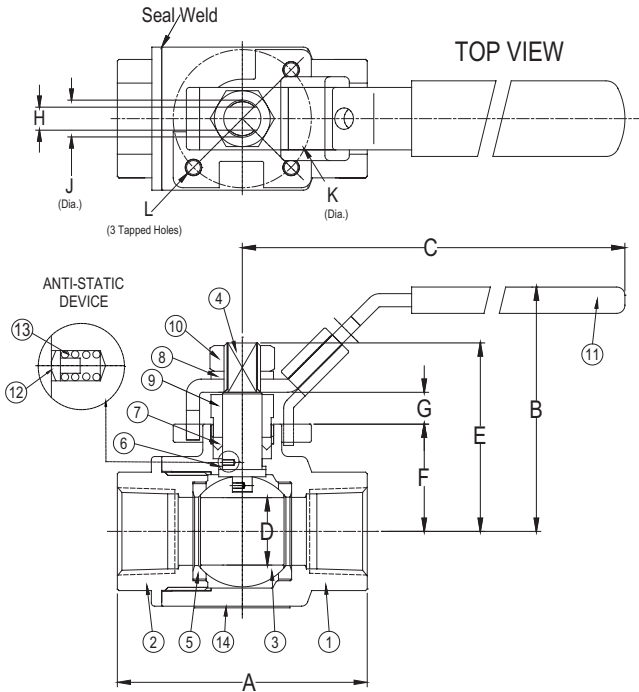

Style BVSC

Seal Welded High Pressure Ball Valve
NPT or Socket Weld Ends*

PARTS LIST			
ITEM	DESCRIPTION	MATERIAL	
1	Body	A 216 Gr. WCB	A 351 Gr. CF8M
2	Tailpiece	A 216 Gr. WCB	A 351 Gr. CF8M
3	Ball	A 276 Gr. 316	A 276 Gr. 316
4	Stem	A 276 Gr. 316	A 276 Gr. 316
5	Seat (2) [†]	R-PTFE	R-PTFE
6	Thrust Washer	R-PTFE	R-PTFE
7	Stem Packing	Graphite	Graphite
8	Spring Washer	304SS	304SS
9	Packing Gland	A 276 Gr. 316	A 276 Gr. 316
10	Lock Nut	304SS	304SS
11	Handle	300 Series SS	300 Series SS
12	Grounding Pin	316SS	316SS
13	Grounding Spring	304SS	304SS
14	Nameplate	304SS	304SS

*Note: Socket Weld Wnds require PEEK seats.
†Optional PEEK Seats for High Temp Service are available.

SIZE		DIMENSIONS														WEIGHTS	
		A		B		C		D		E		F		G			
in	mm	in	mm	in	mm	in	mm	in	mm	in	mm	in	mm	in	mm	lbs	kgs
1/4	8	2.7	68.6	2.2	55.9	5.1	129.5	0.43	11.0	1.53	38.86	0.92	23.37	0.21	5.33	1.0	0.5
3/8	10	2.7	68.6	2.2	55.9	5.1	129.5	0.43	11.0	1.53	38.86	0.92	23.37	0.21	5.33	1.0	0.5
1/2	15	2.7	68.6	2.2	55.9	5.1	129.5	0.50	12.7	1.53	38.86	0.92	23.37	0.21	5.33	1.0	0.5
3/4	20	3.0	76.2	2.8	71.1	5.7	144.8	0.81	20.5	2.26	57.40	1.30	33.02	0.37	9.40	2.0	0.9
1	25	3.7	94.0	3.1	78.7	5.7	144.8	1.00	25.4	2.49	63.25	1.47	37.34	0.41	10.41	3.7	1.7
1-1/4	32	4.0	101.6	3.6	91.4	7.3	185.4	1.25	31.8	2.92	74.17	1.77	44.96	0.44	11.18	4.7	2.1
1-1/2	40	4.5	114.3	3.8	96.5	7.8	198.1	1.50	38.1	3.18	80.77	2.02	51.31	0.48	12.19	6.7	3.0
2	50	5.0	127.0	4.4	111.8	7.8	198.1	2.00	50.0	3.64	92.46	2.38	60.45	0.55	13.97	11.1	5.0

Certified dimensional drawings are available upon request.
†This table reflects only the nearest metric equivalents.

SIZE		DIMENSIONS							ISO PATTERN
		H		J		K		L	
in	mm	in	mm	in	mm	in	mm	in	
1/4	8	0.20	5.08	0.31	7.87	1.42	36.0	1/4"-20 UNC	
3/8	10	0.20	5.08	0.31	7.87	1.42	36.0	1/4"-20 UNC	
1/2	15	0.20	5.08	0.31	7.87	1.42	36.0	1/4"-20 UNC	
3/4	20	0.28	7.11	0.44	11.18	1.65	42.0	1/4"-20 UNC	
1	25	0.28	7.11	0.44	11.18	1.65	42.0	1/4"-20 UNC	
1-1/4	32	0.35	8.89	0.56	14.22	1.97	50.0	1/4"-20 UNC	
1-1/2	40	0.35	8.89	0.56	14.22	1.97	50.0	1/4"-20 UNC	
2	50	0.35	8.89	0.56	14.22	1.97	50.0	1/4"-20 UNC	

Certified dimensional drawings are available upon request.
†This table reflects only the nearest metric equivalents.

PRESSURE vs. TEMPERATURE CHART

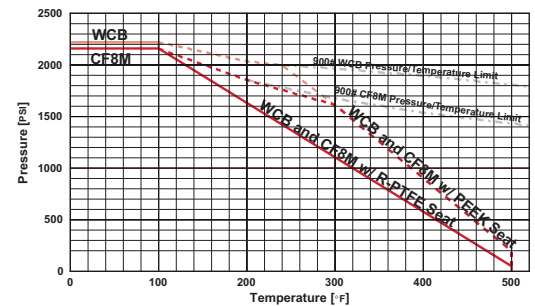

FLOW COEFFICIENTS

Size	C _v	Size	C _v	Size	C _v
1/4"	10	3/4"	32	1-1/2"	140
3/8"	10	1"	62	2"	365
1/2"	18	1-1/4"	115		

MAX TORQUE

Size	in/lb	Size	in/lb	Size	in/lb
1/4"	50	3/4"	120	1-1/2"	400
3/8"	50	1"	180	2"	600
1/2"	75	1-1/4"	300		

Style BVS3

Ball Valve

Carbon Steel (ASTM A 216, Grade WCB)

Stainless Steel (ASTM A 351, Grade CF8M)

NPT or Socket Weld Ends



Seal Welded High Pressure Ball Valve

APPLICATIONS

Industrial and Oil/Gas piping applications where the safety of seal welded construction is desired, any application that requires ASME B16.34 Class 1500 compliance and/or compliance with API 608, and operating pressures are 3600 PSIG or lower.

CONSTRUCTION

Keckley Style BVS3 seal welded high pressure ball valves are constructed from investment cast ASTM grade materials that are NACE MR0175 compliant. They are machined to exacting specifications. Full seal welding of body to tailpiece eliminates the possibility of the tailpiece unthreading, leaking or “blowing out” in service. All valves are shell and seat tested in accordance with API 598. ASME B16.34 Class 1500 compliance provides full conformance to ASME B31 Piping Codes.

FEATURES

- Seal Welded Construction
- Fully Compliant to ASME B16.34 Class 1500
- Fully Compliant to API 608
- API 607 6th Edition Fire-Safe
- Full and Reduced Port Sizes are available
- All Models are NACE MR0175 Compliant
- Elongated Packing Gland for Ease of Access When Automated
- Standard ISO Actuator Mounting Pads on All Sizes
- Standard Locking Stainless Steel Handles
- Electrically Grounded Stem
- Optional PEEK Seats for High Temp Services

ORDERING

Reference *How to Order BVS3 Ball Valves* for building the Keckley Product Number.

WORKING PRESSURES - NON SHOCK

MATERIAL	MEDIA	1/4" to 2"	8 mm to 50 mm
ASTM A 216, Grade WCB	W.O.G.	3705 PSI @ 100°F	15306 KPa @ 38°C
	Saturated Steam (WSP)	Delrin AF Seats No Steam Rating	Delrin AF Seats No Steam Rating
		Optional PEEK Seats 250 PSI @ 406°F	Optional PEEK Seats 1724 KPa @ 208°C
MATERIAL	MEDIA	1/4" to 2"	8 mm to 50 mm
ASTM A 351, Grade CF8M	W.O.G.	3600 PSI @ 100°F	24821 KPa @ 38°C
	Saturated Steam (WSP)	Delrin AF Seats No Steam Rating	Delrin AF Seats No Steam Rating
		Optional PEEK Seats 250 PSI @ 406°F	Optional PEEK Seats 1724 KPa @ 208°C

Note: Optional PEEK Seats WSP is 250 PSIG @ 406°F (1724 KPa @ 208°C)

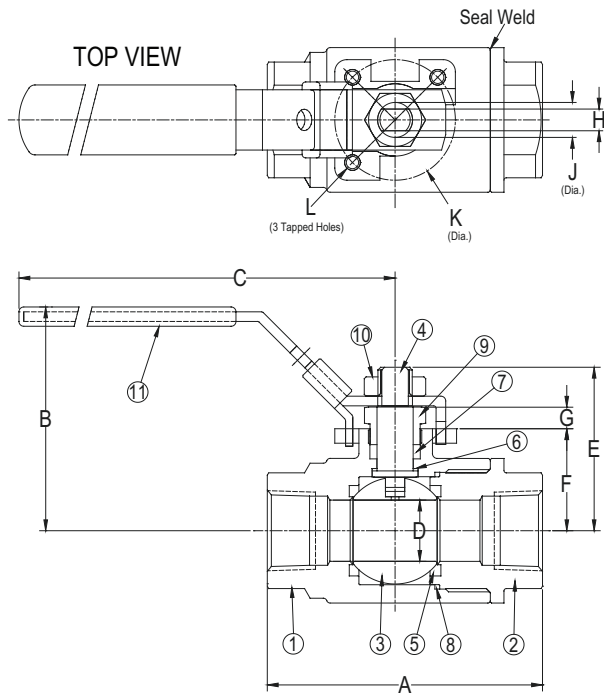

Style BVS3

Seal Welded High Pressure Ball Valve
NPT or Socket Weld Ends*

PARTS LIST			
ITEM	DESCRIPTION	MATERIAL	
1	Body	A 216 Gr. WCB	A 351 Gr. CF8M
2	Tailpiece	A 216 Gr. WCB	A 351 Gr. CF8M
3	Ball	A 276 Gr. 316	A 276 Gr. 316
4	Stem*	A 276 Gr. 316	A 276 Gr. 316
5	Seat (2) [†]	Delrin AF	Delrin AF
6	Thrust Washer	Delrin AF	Delrin AF
7	Stem Packing	Graphite	Graphite
8	Body Seal	Graphite	Graphite
9	Packing Gland	A 276 Gr. 316	A 276 Gr. 316
10	Lock Nut	304SS	304SS
11	Handle	300 Series SS	300 Series SS

*Note: Socket Weld Ends require PEEK seats.
*Size 1-1/2" & 2" S17400 SS.
†Optional PEEK Seats for High Temp Service are available.

SIZE		DIMENSIONS														WEIGHTS	
		A		B		C		D		E		F		G			
in (Port)	mm	in	mm	in	mm	in	mm	in	mm	in	mm	in	mm	in	mm	lbs	kgs
1/4 (FP)	8	3.0	76.2	2.4	61.0	5.1	129.6	0.25	6.4	1.63	41.41	0.89	22.61	0.42	10.67	1.6	0.7
3/8 (RP)	10	3.0	76.2	2.4	61.0	5.1	129.6	0.25	6.4	1.63	41.41	0.89	22.61	0.42	10.67	1.6	0.7
1/2 (FP)	15	4.0	101.6	2.4	61.0	5.1	129.6	0.50	12.7	1.63	41.41	0.89	22.61	0.42	10.67	1.8	0.8
3/4 (FP)	20	4.3	109.3	3.0	76.2	5.6	142.3	0.75	19.1	2.22	56.39	1.29	32.77	0.42	10.67	3.1	1.4
1 (RP)	25	4.3	109.3	3.0	76.2	5.6	142.3	0.75	19.1	2.22	56.39	1.29	32.77	0.42	10.67	2.9	1.3
1 (FP)	32	4.5	114.3	3.5	88.9	7.4	188.0	1.00	25.4	2.80	71.12	1.65	41.91	0.43	10.93	4.4	2.0
1-1/2 (FP)	40	5.3	134.7	4.6	116.9	14.0	355.6	1.50	38.1	3.87	98.30	2.49	63.25	0.52	13.21	10.9	4.9
2 (RP)	50	6.3	160.1	4.6	116.9	14.0	355.6	1.50	38.1	3.87	98.30	2.49	63.25	0.52	13.21	12.3	5.6

Certified dimensional drawings are available upon request.
†This table reflects only the nearest metric equivalents.

SIZE		DIMENSIONS								ISO PATTERN
		H		J		K		L		
in (Port)	mm	in	mm	in	mm	in	mm	in		
1/4 (FP)	8	0.20	5.08	0.31	7.88	1.42	36.0	1/4"-20 UNC	F03	
3/8 (RP)	10	0.20	5.08	0.31	7.88	1.42	36.0	1/4"-20 UNC	F03	
1/2 (FP)	15	0.20	5.08	0.31	7.88	1.42	36.0	1/4"-20 UNC	F03	
3/4 (FP)	20	0.28	7.12	0.44	11.18	1.65	42.0	1/4"-20 UNC	F04	
1 (RP)	25	0.28	7.12	0.44	11.18	1.65	42.0	1/4"-20 UNC	F04	
1 (FP)	32	0.35	8.89	0.56	14.23	1.97	50.0	1/4"-20 UNC	F05	
1-1/2 (FP)	40	0.39	9.91	0.62	15.75	2.76	70.0	5/16"-18 UNC	F07	
2 (RP)	50	0.39	9.91	0.62	15.75	2.76	70.0	5/16"-18 UNC	F07	

Certified dimensional drawings are available upon request.
†This table reflects only the nearest metric equivalents.

PRESSURE vs. TEMPERATURE CHART

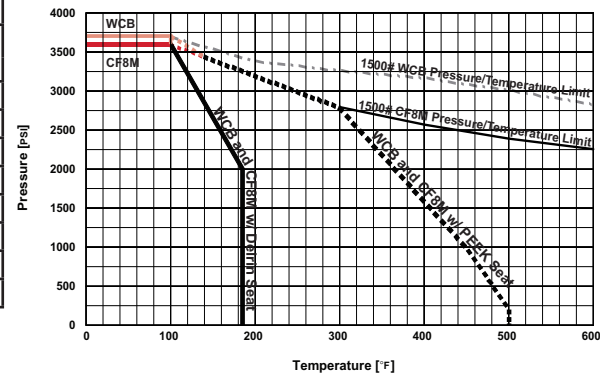

FLOW COEFFICIENTS

Size (Port)	C _v	Size (Port)	C _v	Size (Port)	C _v
1/4" (FP)	10	3/4" (FP)	32	1-1/2" (FP)	140
3/8" (RP)	10	1" (RP)	45	2" (RP)	125
1/2" (FP)	16	1" (FP)	65		

MAX TORQUE

Size (Port)	in/lb (Delrin AF)	in/lb (PEEK)	Size (Port)	in/lb (Delrin AF)	in/lb (PEEK)	Size (Port)	in/lb (Delrin AF)	in/lb (PEEK)
1/4" (FP)	75	100	3/4" (FP)	120	270	1-1/2" (FP)	750	1200
3/8" (RP)	75	100	1" (RP)	200	270	2" (RP)	750	1200
1/2" (FP)	75	100	1" (FP)	400	700			

Style BVS6

Ball Valve

Carbon Steel (ASTM A 216, Grade WCB)

Stainless Steel (ASTM A 351, Grade CF8M)

NPT or Socket Weld Ends



Seal Welded High Pressure Ball Valve

APPLICATIONS

Industrial and Oil/Gas piping applications where the safety of seal welded construction is desired, any application that requires ASME B16.34 Class 2500 compliance and/or compliance with API 608, and operating pressures are 6000 PSIG or lower.

CONSTRUCTION

Keckley Style BVS6 seal welded high pressure ball valves are constructed from investment cast ASTM grade materials that are NACE MR0175 compliant. They are machined to exacting specifications. Full seal welding of body to tailpiece eliminates the possibility of the tailpiece unthreading, leaking or “blowing out” in service. All valves are shell and seat tested in accordance with API 598. ASME B16.34 Class 2500 compliance provides full conformance to ASME B31 Piping Codes.

FEATURES

- Seal Welded Construction
- Fully Compliant to ASME B16.34 Class 2500
- Fully Compliant to API 608
- API 607 6th Edition Fire-Safe
- Full and Reduced Port Sizes are available
- All Models are NACE MR0175 Compliant
- Elongated Packing Gland for Ease of Access When Automated
- Standard ISO Actuator Mounting Pads on All Sizes
- Standard Locking Stainless Steel Handles
- Electrically Grounded Stem
- Optional PEEK Seats for High Temp Services

ORDERING

Reference *How to Order BVS6 Ball Valves* for building the Keckley Product Number.

WORKING PRESSURES - NON SHOCK

MATERIAL	MEDIA	¼" to 2"	8 mm to 50 mm
ASTM A 216, Grade WCB	W.O.G.	6170 PSI @ 100°F	42541 KPa @ 38°C
	Saturated Steam (WSP)	250 PSI @ 406°F	1724 KPa @ 208°C
MATERIAL	MEDIA	¼" to 2"	8 mm to 50 mm
ASTM A 351, Grade CF8M	W.O.G.	6000 PSI @ 100°F	41369 KPa @ 38°C
	Saturated Steam (WSP)	250 PSI @ 406°F	1724 KPa @ 208°C

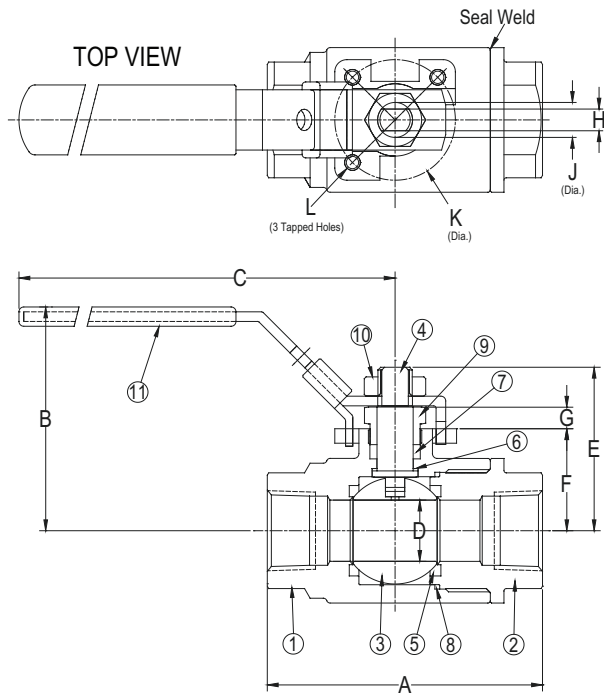

Style BVS6

Seal Welded High Pressure Ball Valve
NPT or Socket Weld Ends.

PARTS LIST			
ITEM	DESCRIPTION	MATERIAL	
1	Body	A 216 Gr. WCB	A 351 Gr. CF8M
2	Tailpiece	A 216 Gr. WCB	A 351 Gr. CF8M
3	Ball	A 276 Gr. 316	A 276 Gr. 316
4	Stem	S17400 SS	S17400 SS
5	Seat (2)	PEEK	PEEK
6	Thrust Washer	PEEK	PEEK
7	Stem Packing	Graphite	Graphite
8	Body Seal	Graphite	Graphite
9	Packing Gland	A 276 Gr. 316	A 276 Gr. 316
10	Lock Nut	304SS	304SS
11	Handle	300 Series SS	300 Series SS

SIZE		DIMENSIONS														WEIGHTS	
		A		B		C		D		E		F		G			
in (Port)	mm	in	mm	in	mm	in	mm	in	mm	in	mm	in	mm	in	mm	lbs	kgs
1/4 (FP)	8	3.0	76.2	2.4	61.0	5.1	129.6	0.25	6.4	1.63	41.41	0.89	22.61	0.42	10.67	1.7	0.8
3/8 (RP)	10	3.0	76.2	2.4	61.0	5.1	129.6	0.25	6.4	1.63	41.41	0.89	22.61	0.42	10.67	1.7	0.8
1/2 (FP)	15	4.0	101.6	2.4	61.0	5.1	129.6	0.50	12.7	1.63	41.41	0.89	22.61	0.42	10.67	2.1	1.0
3/4 (FP)	20	4.3	109.3	3.0	76.2	5.6	142.3	0.75	19.1	2.22	56.39	1.29	32.77	0.42	10.67	3.5	1.6
1 (RP)	25	4.3	109.3	3.0	76.2	5.6	142.3	0.75	19.1	2.22	56.39	1.29	32.77	0.42	10.67	4.0	1.8
1 (FP)	32	4.5	114.3	3.5	88.9	7.4	188.0	1.00	25.4	2.80	71.12	1.65	41.91	0.43	10.93	6.0	2.7
1-1/2 (FP)	40	5.3	134.7	4.6	116.9	14.0	355.6	1.50	38.1	3.87	98.30	2.47	62.74	0.54	13.72	13.7	6.2
2 (RP)	50	6.3	160.1	4.6	116.9	14.0	355.6	1.50	38.1	3.87	98.30	2.47	62.74	0.54	13.72	16.5	7.5

Certified dimensional drawings are available upon request.
*This table reflects only the nearest metric equivalents.

SIZE		DIMENSIONS							ISO PATTERN
		H		J		K		L	
in (Port)	mm	in	mm	in	mm	in	mm	in	
1/4 (FP)	8	0.20	5.08	0.31	7.88	1.42	36.0	1/4"-20 UNC	
3/8 (RP)	10	0.20	5.08	0.31	7.88	1.42	36.0	1/4"-20 UNC	
1/2 (FP)	15	0.20	5.08	0.31	7.88	1.42	36.0	1/4"-20 UNC	
3/4 (FP)	20	0.28	7.12	0.44	11.18	1.65	42.0	1/4"-20 UNC	
1 (RP)	25	0.28	7.12	0.44	11.18	1.65	42.0	1/4"-20 UNC	
1 (FP)	32	0.35	8.89	0.56	14.23	1.97	50.0	1/4"-20 UNC	
1-1/2 (FP)	40	0.39	9.91	0.62	15.75	2.76	70.0	5/16"-18 UNC	
2 (RP)	50	0.39	9.91	0.62	15.75	2.76	70.0	5/16"-18 UNC	

Certified dimensional drawings are available upon request.
*This table reflects only the nearest metric equivalents.

PRESSURE vs. TEMPERATURE CHART

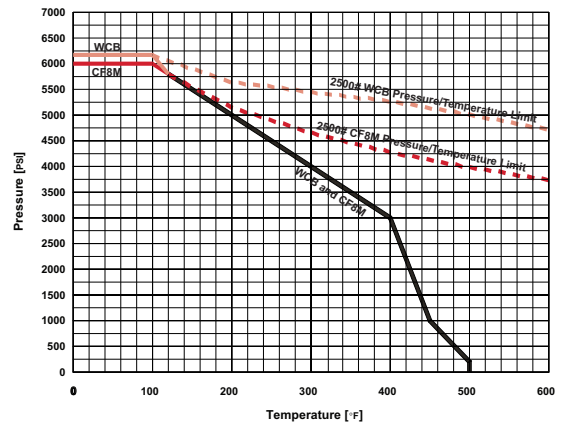

FLOW COEFFICIENTS

Size (Port)	C _v	Size (Port)	C _v	Size (Port)	C _v
1/4" (FP)	10	3/4" (FP)	32	1-1/2" (FP)	140
3/8" (RP)	10	1" (RP)	45	2" (RP)	125
1/2" (FP)	16	1" (FP)	65		

MAX TORQUE

Size (Port)	in/lb	Size (Port)	in/lb	Size (Port)	in/lb
1/4" (FP)	100	3/4" (FP)	270	1-1/2" (FP)	1200
3/8" (RP)	100	1" (RP)	270	2" (RP)	1200
1/2" (FP)	130	1" (FP)	700		

Style BVM3

Ball Valve

Carbon Steel (ASTM A 216, Grade WCB)

Stainless Steel (ASTM A 351, Grade CF8M)

NPT, Socket Weld, Butt Weld,
Extended Socket Weld and
Extended Butt Weld Ends



3-Piece Maintenance Design Ball Valve

APPLICATIONS

Industrial and Oil/Gas piping applications where 3-Piece construction is desired/required to facilitate future maintenance and repair, weld-in applications requiring valve disassembly to protect internal components during the welding process, and applications that require ASME B16.34 and API 608 compliance leading to ASME B31.1 and B31.3 Code Compliance.

CONSTRUCTION

Keckley Style BVM3 3-Piece Maintenance Design Ball Valves employ investment cast ASTM Grade materials that are properly heat-treated and chemically finished to insure proper corrosion resistance, strength and NACE MR0175 compliance. The BVM3 series body bolts and threaded body center section insures superior body seal retention/sealing under high piping stress and elevated temperature applications. All sizes comply with ASME B16.34 and API 608 Standards for Class 800 service. Available extended socket weld and butt weld ends allow welding into the piping without disassembly. Each valve is tested to API 598, and all valves comply with API 607 6th Edition for Fire-Safe performance.

FEATURES

- 3-Piece Maintenance Design
- ASME B16.34 Class 800 Compliant
- API 608 Class 800 Compliant
- API 607 6th Edition Fire-Safe
- 1/4" - 2" Full Port and 1/2" - 2-1/2" Reduced Port Sizes Available
- All Models are NACE MR0175 Compliant
- Extended Packing Adjustment Nut for ease of adjustment
- ISO 5211 Actuator Mounting Pads on All Sizes
- Standard Locking Stainless Steel Handles
- Electrically Grounded Stem
- Optional PEEK Seats for Elevated Temperature Services
- Optional Locking Stainless Steel Oval Handles
- Extended Topworks Available

ORDERING

Reference *How to Order BVM3 Ball Valves* for building the Keckley Product Number.

WORKING PRESSURES - NON SHOCK

MATERIAL	MEDIA	1/4" to 2-1/2"	8 mm to 65 mm
ASTM A 216, Grade WCB	W.O.G.	1973 PSI @ 100°F	13603 KPa @ 38°C
MATERIAL	MEDIA	1/4" to 2-1/2"	8 mm to 65 mm
ASTM A 351, Grade CF8M	W.O.G.	1920 PSI @ 100°F	13238 KPa @ 38°C
MATERIAL	MEDIA	1/4" to 2-1/2"	8 mm to 65 mm
ASTM A 216, Grade WCB & ASTM A 351, Grade CF8M	Saturated Steam (WSP)	250 PSI @ 406°F	1724 KPa @ 208°C

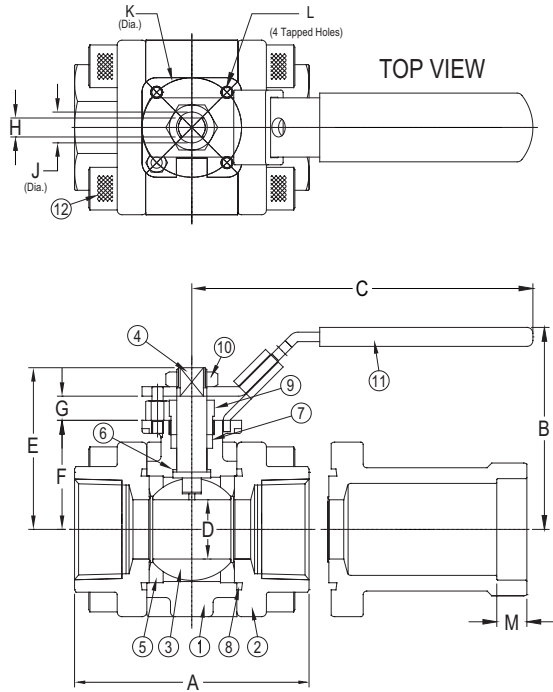

Style BVM3

3-Piece Maintenance Design Ball Valve
NPT, Socket Weld, or Butt Weld Ends.

PARTS LIST			
ITEM	DESCRIPTION	MATERIAL	
1	Body	A 216 Gr. WCB	A 351 Gr. CF8M
2	Tailpiece (2)	A 216 Gr. WCB	A 351 Gr. CF8M
3	Ball	A 276 Gr. 316	A 276 Gr. 316
4	Stem	A 276 Gr. 316	A 276 Gr. 316
5	Seat (2) [†]	R-PTFE	R-PTFE
6	Thrust Washer	R-PTFE	R-PTFE
7	Stem Packing	Graphite	Graphite
8	Body Seal (2)	Graphite	Graphite
9	Packing Gland	A 276 Gr. 316	A 276 Gr. 316
10	Lock Nut	304SS	304SS
11	Handle	300 Series SS	300 Series SS
12	Body Bolts (8)	A 193, Grade B7	A 193, Grade B8

[†]Optional PEEK Seats for High Temp Service are available.

SIZE		DIMENSIONS													
		A NPT OR SW		A EXTENDED SW		B	C	D	E	F	G	H	J	K	L
Reduced Port	Full Port	Reduced Port	Full Port	Reduced Port	Full Port										
1/2	1/4, 3/8	2.7	2.7	6.0	N/A	2.5	4.3	0.43	1.71	1.08	0.31	0.197	0.31	1.42	1/4"-20 UNC
3/4	1/2	3.0	2.8	7.0	7.0	2.6	4.3	0.57	1.83	1.24	0.31	0.197	0.31	1.42	1/4"-20 UNC
1	3/4	3.5	3.2	7.5	7.5	3.0	5.7	0.81	2.34	1.50	0.37	0.276	0.44	1.65	1/4"-20 UNC
1-1/4	1	3.9	3.8	8.0	8.0	3.4	5.8	1.00	2.69	1.81	0.40	0.315	0.50	1.65	1/4"-20 UNC
1-1/2	1-1/4	4.5	4.3	8.0	8.0	3.7	7.5	1.25	2.91	1.95	0.43	0.394	0.62	1.97	1/4"-20 UNC
2	1-1/2	5.0	4.8	9.0	9.0	3.9	7.5	1.50	3.15	2.26	0.35	0.394	0.62	1.97	1/4"-20 UNC
2-1/2	2	6.9	5.7	N/A	10.0	5.3	11.7	2.00	4.37	3.11	0.49	0.472	0.75	2.76	5/16"-18 UNC

Certified dimensional drawings are available upon request.

[†]This table reflects only the nearest metric equivalents.

SIZE		DIMENSIONS				WEIGHT (lbs)	FLOW COEFFICIENTS		MAX TORQUE in/lb
		M		ISO PATTERN	C _v				
Reduced Port	Full Port	Reduced Port	Full Port				Reduced Port	Full Port	
1/2	1/4, 3/8	0.38	N/A	F03	1.7	10	10	100	
3/4	1/2	0.50	0.38	F03	2.2	25	22	200	
1	3/4	0.50	0.50	F04	3.8	42	40	230	
1-1/4	1	0.50	0.50	F04	5.1	55	62	250	
1-1/2	1-1/4	0.50	0.50	F05	7.1	85	115	380	
2	1-1/2	0.62	0.50	F05	9.8	120	140	520	
2-1/2	2	N/A	0.62	F07	20.8	300	360	660	

Certified dimensional drawings are available upon request.

[†]This table reflects only the nearest metric equivalents.

PRESSURE vs. TEMPERATURE CHART

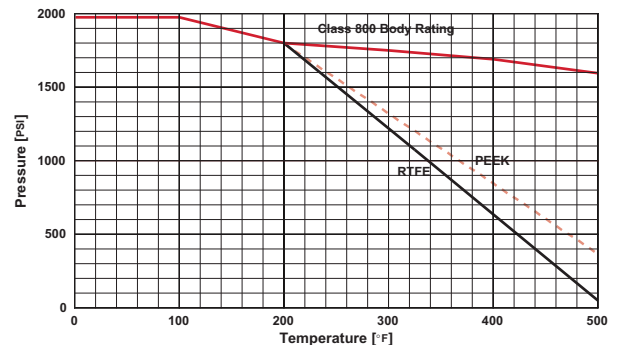

Style BVF1

Ball Valve

Carbon Steel (ASTM A 216, Grade WCB)

150 lb. & 300 lb. Flanged

Stainless Steel (ASTM A 351, Grade CF8M)

150 lb. & 300 lb. Flanged

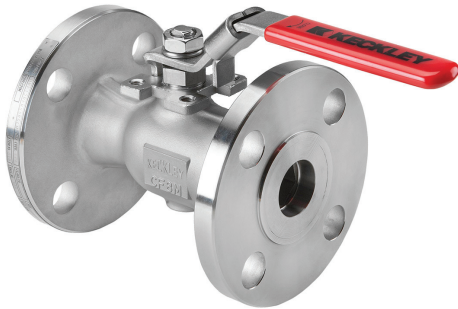

Unibody Flanged Ball Valve

1/2" - 1"

APPLICATIONS

Industrial and Oil/Gas piping applications requiring ASME Class 150 or 300 flanged end ball valves with one-piece body construction.

CONSTRUCTION

The Keckley Style BVF1 Unibody flanged end ball valves are constructed from rugged investment castings that are machined to exacting specifications. Unibody construction provides high structural strength and minimizes external leak paths.

FEATURES

- Unibody Construction
- Fully Compliant to ASME B16.34
- Fully Compliant to API 608
- API 607 6th Edition Fire-Safe
- All Models are NACE MR0175 Compliant
- Elongated Packing Gland for Ease of Access When Automated
- Standard ISO Actuator Mounting Pads on All Sizes
- Standard Locking Stainless Steel Handles
- Second Generation PTFE Seats Provide Higher Operating Temperatures
- Standard Electrically Grounded Ball & Stem
- Optional Oval Handles

ORDERING

Reference *How to Order BVF1 Ball Valves* for building the Keckley Product Number.

WORKING PRESSURES - NON SHOCK

NOM. RATING	MATERIAL	MEDIA	1/2" to 1"	15 mm to 25 mm
ASME CLASS 150	A 216, WCB	W.O.G.	285 PSI @ 100°F	1965 KPa @ 38°C
		Saturated Steam (WSP)	200 PSI @ 388°F	1379 KPa @ 198°C
	MATERIAL	MEDIA	1/2" to 1"	15 mm to 25 mm
	A 351, CF8M	W.O.G.	275 PSI @ 100°F	1896 KPa @ 38°C
Saturated Steam (WSP)		195 PSI @ 386°F	1344 KPa @ 197°C	
NOM. RATING	MATERIAL	MEDIA	1/2" to 1"	15 mm to 25 mm
ASME CLASS 300	A 216, WCB	W.O.G.	740 PSI @ 100°F	5102 KPa @ 38°C
		Saturated Steam (WSP)	250 PSI @ 406°F	1724 KPa @ 208°C
	MATERIAL	MEDIA	1/2" to 1"	15 mm to 25 mm
	A 351, CF8M	W.O.G.	720 PSI @ 100°F	4964 KPa @ 38°C
Saturated Steam (WSP)		250 PSI @ 406°F	1724 KPa @ 208°C	

Style BVF1

Unibody Flanged Ball Valve

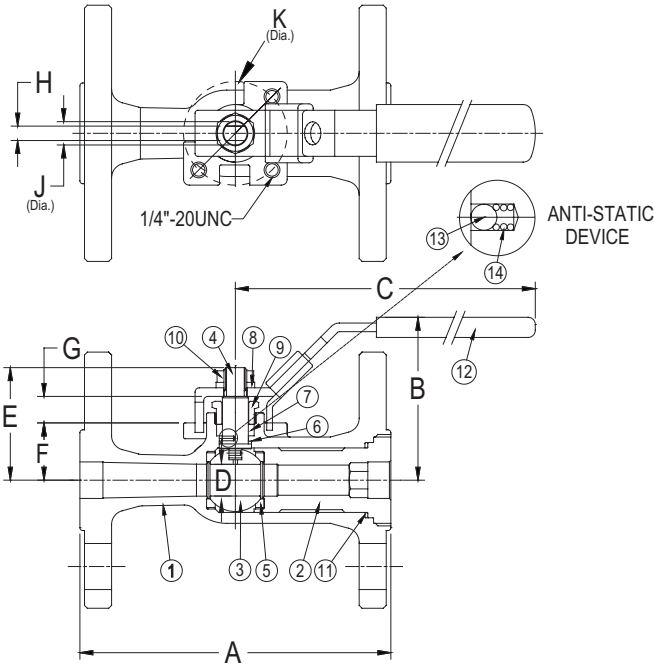

PARTS LIST			
ITEM	DESCRIPTION	MATERIAL	
1	Body	A 216, WCB	A 351, CF8M
2	Tailpiece	A 216, WCB	A 351, CF8M
3	Ball	A 351, CF8M or 316SS	A 351, CF8M or 316SS
4	Stem	A 276, 316	A 276, 316
5	Seat (2)	R-PTFE	R-PTFE
6	Thrust Washer	PTFE	PTFE
7	Stem Packing	Graphite	Graphite
8	Lock Washer	304SS	304SS
9	Packing Gland	A 276, 316	A 276, 316
10	Lock Nut	304SS	304SS
11	Body Gasket	Graphite	Graphite
12	Handle Assembly	300 Series SS	300 Series SS
13	Grounding Ball (2)	304SS	304SS
14	Grounding Spring (2)	304SS	304SS

SIZE		DIMENSIONS															
		A		B		C		D		E		F		G			
		150 lb.		300 lb.		150 lb. & 300 lb.		150 lb. & 300 lb.		150 lb. & 300 lb.		150 lb. & 300 lb.		150 lb. & 300 lb.			
in	mm	in	mm	in	mm	in	mm	in	mm	in	mm	in	mm	in	mm	in	mm
1/2	15	4.25	108.0	5.50	139.7	2.21	56.1	5.04	128.01	0.43	10.92	1.53	38.86	0.78	19.81	0.350	8.89
3/4	20	4.62	117.3	6.00	152.4	2.72	69.1	5.63	143.00	0.59	15.00	2.06	52.32	1.03	26.16	0.425	10.80
1	25	5.00	127.0	6.50	165.1	2.98	75.7	5.63	143.00	0.81	20.57	2.33	59.18	1.33	33.78	0.402	10.21

Certified dimensional drawings are available upon request.
†This table reflects only the nearest metric equivalents.

SIZE		DIMENSIONS								WEIGHTS			
		H		J		K		ISO PATTERN	150 lb.		300 lb.		
		in	mm	in	mm	in	mm		lbs	kgs	lbs	kgs	
1/2	15	0.20	5.08	0.31	7.87	1.42	36.0	F03	2.7	1.2	4.7	2.1	
3/4	20	0.28	7.11	0.44	11.18	1.65	42.0	F04	4.3	2.0	7.2	3.3	
1	25	0.28	7.11	0.44	11.18	1.65	42.0	F04	5.7	2.6	8.1	3.7	

Certified dimensional drawings are available upon request.
†This table reflects only the nearest metric equivalents.

FLOW COEFFICIENTS

Size	C _v	Size	C _v	Size	C _v
1/2"	16	3/4"	27	1"	42

MAX TORQUE

Size	in/lb	Size	in/lb	Size	in/lb
1/2"	100	3/4"	130	1"	150

PRESSURE vs. TEMPERATURE CHART

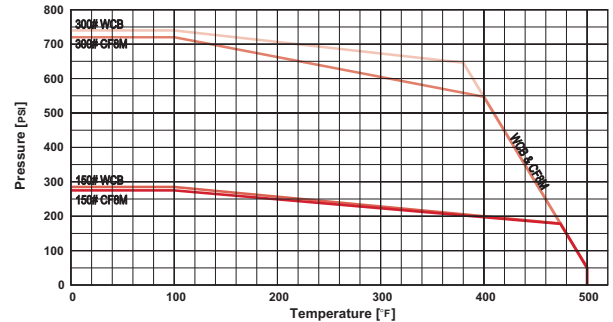

Style BVF1

Ball Valve

Carbon Steel (ASTM A 216, Grade WCB)

150 lb. & 300 lb. Flanged

Stainless Steel (ASTM A 351, Grade CF8M)

150 lb. & 300 lb. Flanged

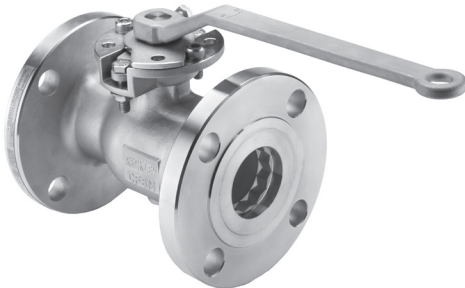

Unibody Flanged Ball Valve

1-1/2" - 6"

APPLICATIONS

Industrial and Oil/Gas piping applications requiring ASME Class 150 or 300 flanged end ball valves with one-piece body construction.

CONSTRUCTION

The Keckley Style BVF1 Unibody flanged end ball valves are constructed from rugged investment castings that are machined to exacting specifications. Unibody construction provides high structural strength and minimizes external leak paths.

FEATURES

- Unibody Construction
- Fully Compliant to ASME B16.34
- Fully Compliant to API 608
- API 607 6th Edition Fire-Safe
- All Models are NACE MR0175 Compliant
- Submerged Packing System & Direct-Mount Actuation
- Standard ISO Actuator Mounting Pads on All Sizes
- Standard Locking Stainless Steel Handles
- Second Generation PTFE Seats Provide Higher Operating Temperatures
- Standard Electrically Grounded Ball & Stem

ORDERING

Reference *How to Order BVF1 Ball Valves* for building the Keckley Product Number.

WORKING PRESSURES - NON SHOCK

NOM. RATING	MATERIAL	MEDIA	1-1/2" to 6"	40 mm to 150 mm
ASME CLASS 150	A 216, WCB	W.O.G.	285 PSI @ 100°F	1965 KPa @ 38°C
		Saturated Steam (WSP)	200 PSI @ 388°F	1379 KPa @ 198°C
	MATERIAL	MEDIA	1-1/2" to 6"	40 mm to 150 mm
	A 351, CF8M	W.O.G.	275 PSI @ 100°F	1896 KPa @ 38°C
Saturated Steam (WSP)		195 PSI @ 386°F	1344 KPa @ 197°C	
NOM. RATING	MATERIAL	MEDIA	1-1/2" to 6"	40 mm to 150 mm
ASME CLASS 300	A 216, WCB	W.O.G.	740 PSI @ 100°F	5102 KPa @ 38°C
		Saturated Steam (WSP)	250 PSI @ 406°F	1724 KPa @ 208°C
	MATERIAL	MEDIA	1-1/2" to 6"	40 mm to 150 mm
	A 351, CF8M	W.O.G.	720 PSI @ 100°F	4964 KPa @ 38°C
Saturated Steam (WSP)		250 PSI @ 406°F	1724 KPa @ 208°C	

Style BVF1

Unibody Flanged Ball Valve

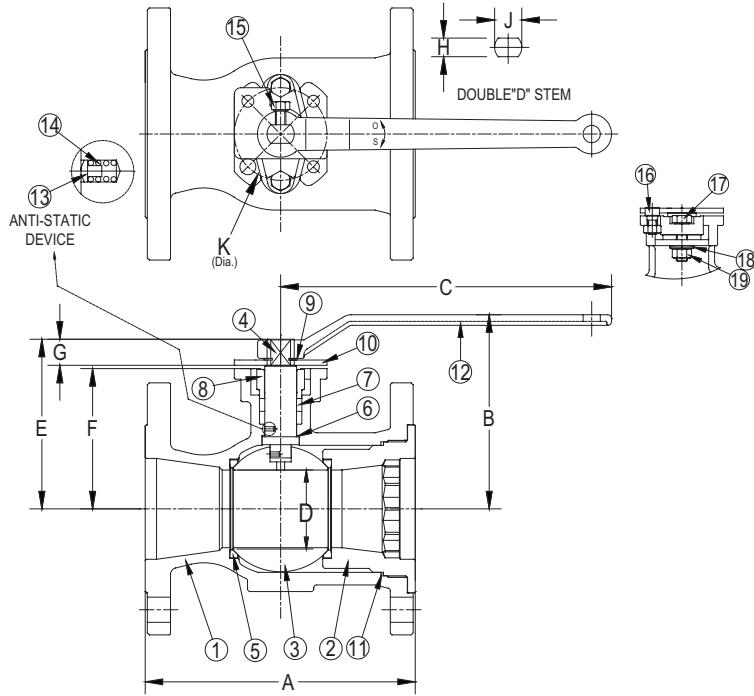

PARTS LIST			
ITEM	DESCRIPTION	MATERIAL	
1	Body	A 216, WCB	A 351, CF8M
2	Tailpiece	A 216, WCB	A 351, CF8M
3	Ball	A 351, CF8M or 316SS	A 351, CF8M or 316SS
4	Stem	A 276, 316	A 276, 316
5	Seat (2)	R-PTFE	R-PTFE
6	Thrust Washer	PTFE	PTFE
7	Stem Packing	Graphite	Graphite
8	Packing Gland	A 351, CF8M	A 351, CF8M
9	Retaining Ring	300 Series SS	300 Series SS
10	Lock Plate	304SS	304SS
11	Body Gasket	Graphite	Graphite
12	Handle Assembly	300 Series SS	300 Series SS
13	Grounding Ball (2)	304SS	304SS
14	Grounding Spring (2)	304SS	304SS
15	Handle Bolt	304SS	304SS
16	Stop Bolt	304SS	304SS
17	Packing Bolt (2)	A 193, B8	A 193, B8
18	Belleville Washers	300 Series SS	300 Series SS
19	Packing Nut (2)	A 194, Grade 8	A 194, Grade 8

SIZE		DIMENSIONS															
		A				B				C		D		E			
		150 lb.		300 lb.		150 lb.		300 lb.		150 lb. & 300 lb.		150 lb. & 300 lb.		150 lb.		300 lb.	
in	mm	in	mm	in	mm	in	mm	in	mm	in	mm	in	mm	in	mm	in	mm
1-1/2	40	6.5	165.1	7.50	190.5	4.07	103.38	4.07	103.38	10.02	254.51	1.19	30.23	3.33	84.58	3.33	84.58
2	50	7.0	177.8	8.50	215.9	4.61	117.09	4.83	122.68	10.02	254.51	1.50	38.10	3.87	98.30	4.08	103.63
*2-1/2	65	7.5	190.5	N/A		5.35	135.89	N/A		10.02	254.51	2.00	50.80	4.61	117.09	N/A	
3	80	8.0	203.2	11.12	284.5	5.73	145.54	5.73	145.54	10.02	254.51	2.31	58.67	4.99	126.75	4.99	126.75
4	100	9.0	228.6	12.00	304.8	6.71	170.43	6.99	177.55	18.11	459.99	2.99	75.95	6.14	155.96	6.42	163.07
6	150	10.5	266.7	15.88	403.4	8.43	214.12	8.43	214.12	18.11	459.99	4.49	114.05	7.85	199.39	7.85	199.69

SIZE		DIMENSIONS											ISO PATTERN		
		F		G		H		J		K					
		150 lb.		300 lb.		150 lb. & 300 lb.		150 lb. & 300 lb.		150 lb. & 300 lb.		150 lb. & 300 lb.			
in	mm	in	mm	in	mm	in	mm	in	mm	in	mm	in	mm	in	mm
1-1/2	40	2.51	63.75	2.55	64.77	0.76	19.30	0.55	13.97	0.71	18.03	2.76	70.0		F07
2	50	3.07	77.98	3.29	83.57	0.76	19.30	0.55	13.97	0.71	18.03	2.76	70.0		F07
*2-1/2	65	3.80	96.52	N/A		0.76	19.30	0.55	13.97	0.71	18.03	2.76	70.0		F07
3	80	4.17	105.92	4.17	105.92	0.76	19.30	0.55	13.97	0.71	18.03	2.76	70.0		F07
4	100	4.84	122.94	5.12	130.05	1.26	32.00	0.67	17.02	1.03	26.16	4.02	102.0		F10
6	150	6.50	165.10	6.50	165.10	1.26	32.00	0.67	17.02	1.03	26.16	4.02 & 4.92	102.0 & 125.0		F10 & F12

*2-1/2" only offered in 150lb Class.

Certified dimensional drawings are available upon request.

†This table reflects only the nearest metric equivalents.

WEIGHTS

Size	1-1/2"	2"	2-1/2"	3"	4"	6"	
150	lbs	12.5	18.5	27.0	33.0	61.0	99.0
	kgs	5.7	8.4	12.2	15.0	27.7	44.9
300	lbs	20.0	24.0	N/A	49.0	83.0	157.0
	kgs	9.1	10.9	N/A	22.2	37.6	71.2

FLOW COEFFICIENTS

Size	C _v	Size	C _v	Size	C _v
1-1/2"	100	2-1/2"	285	4"	610
2"	145	3"	425	6"	920

MAX TORQUE

Size	in/lb	Size	in/lb	Size	in/lb
1-1/2"	250	2-1/2"	475	4"	1000
2"	400	3"	550	6"	1700

PRESSURE vs. TEMPERATURE CHART

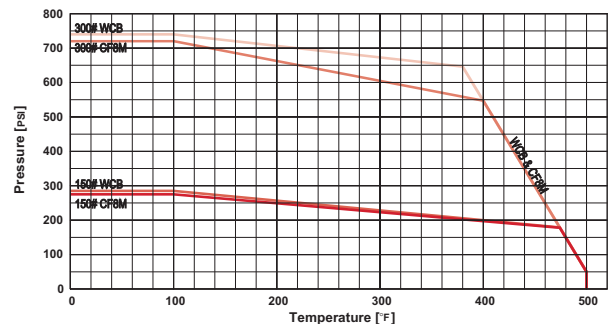

Style BVF2

Ball Valve

Carbon Steel (ASTM A 216, Grade WCB)

150 lb. & 300 lb. Flanged

Stainless Steel (ASTM A 351, Grade CF8M)

150 lb. & 300 lb. Flanged

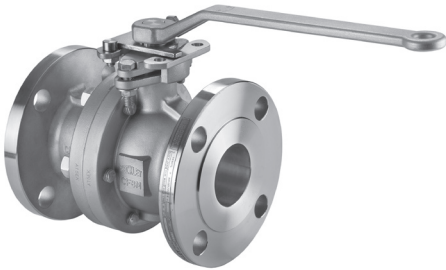

Split-Body Full Port Flanged Ball Valve

1½" - 8" Class 150

1½" - 6" Class 300

APPLICATIONS

Industrial and Oil/Gas piping applications requiring the higher flow capacity and lower pressure drop of full port internal flow-ways, and those applications where ease of reparability is desired.

CONSTRUCTION

The Keckley Style BVF2 Split-Body full port flanged end ball valves employ investment cast and shell cast bodies & tailpieces, all produced from ASTM grade materials that are properly heat treated and chemically finished. All wall thicknesses comply with ASME B16.34 as do bolting stress levels.

FEATURES

- 2-Piece Bolted Body, Full Port Construction
- Fully Compliant to ASME B16.34
- Fully Compliant to API 608
- API 607 6th Edition Fire-Safe
- All Models are NACE MR0175 Compliant
- Submerged Packing System & Direct Mount Actuation
- Standard ISO Actuator Mounting Pads on All Sizes
- Standard Locking Stainless Steel Handles
- Second Generation PTFE Seats Provide Higher Operating Temperatures
- Standard Electrically Grounded Ball & Stem
- All Sizes use Body Studs & Nuts for Ease of Disassembly

ORDERING

Reference *How to Order BVF2 Ball Valves* for building the Keckley Product Number.

WORKING PRESSURES - NON SHOCK

NOM. RATING	MATERIAL	MEDIA	1-½" to 8"	40 mm to 200 mm
ASME CLASS 150	A 216, WCB	W.O.G.	285 PSI @ 100°F	1965 KPa @ 38°C
		Saturated Steam (WSP)	200 PSI @ 388°F	1379 KPa @ 198°C
	MATERIAL	MEDIA	1-½" to 8"	40 mm to 200 mm
	A 351,CF8M	W.O.G.	275 PSI @ 100°F	1896 KPa @ 38°C
Saturated Steam (WSP)		195 PSI @ 386°F	1344 KPa @ 197°C	
NOM. RATING	MATERIAL	MEDIA	1-½" to 6"	40 mm to 150 mm
ASME CLASS 300	A 216, WCB	W.O.G.	740 PSI @ 100°F	5102 KPa @ 38°C
		Saturated Steam (WSP)	250 PSI @ 406°F	1724 KPa @ 208°C
	MATERIAL	MEDIA	1-½" to 6"	40 mm to 150 mm
	A 351, CF8M	W.O.G.	720 PSI @ 100°F	4964 KPa @ 38°C
Saturated Steam (WSP)		250 PSI @ 406°F	1724 KPa @ 208°C	



TECHNICAL DATA
DIMENSIONS AND WEIGHTS

8" Class 150 Stem Design

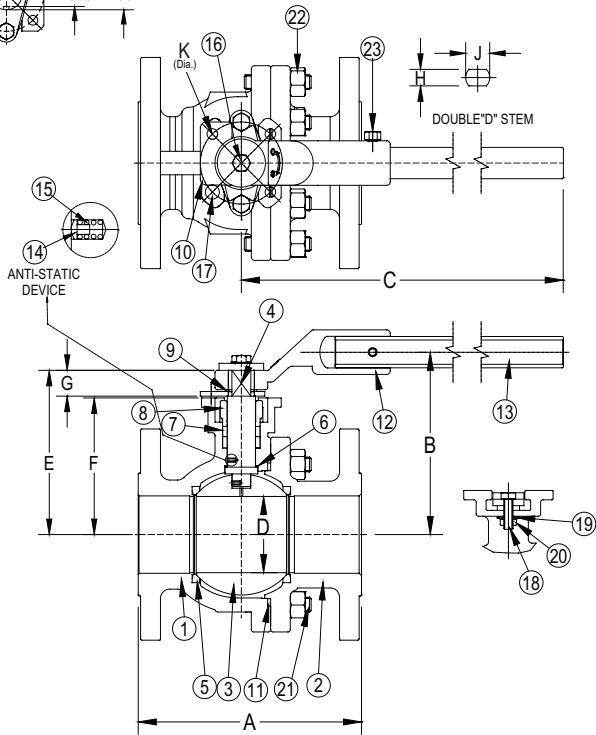
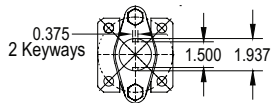

Style BVF2

Split-body Flanged Ball Valve

PARTS LIST			
ITEM	DESCRIPTION	MATERIAL	
1	Body	A 216, WCB	A 351, CF8M
2	Tailpiece	A 216, WCB	A 351, CF8M
3	Ball	A 351, CF8M or 316SS	A 351, CF8M or 316SS
4	Stem	A 276, 316	A 276, 316
5	Seat (2)	R-PTFE	R-PTFE
6	Thrust Washer	PTFE	PTFE
7	Stem Packing	Graphite	Graphite
8	Packing Gland	A 351, CF8M	A 351, CF8M
9	Retaining Ring	300 Series SS	300 Series SS
10	Lock Plate	304SS	304SS
11	Body Gasket	Graphite	Graphite
12	Handle	300 Series SS	300 Series SS
13	Handle Extension*	Carbon Steel	Carbon Steel
14	Grounding Ball (2)	316SS	316SS
15	Grounding Spring (2)	304SS	304SS
16	Handle Bolt	304SS	304SS
17	Stop Bolt	304SS	304SS
18	Packing Bolt (2)	A 193, B8	A 193, B8
19	Belleville Washers	300 Series SS	300 Series SS
20	Packing Nut (2)	A 194, 8	A 194, 8
21	Body Stud Bolts	A 193, B7	A 193, B8
22	Body Nuts	A 194, 2H	A 194, 8
23	Handle Ext. Bolt*	304SS	304SS

Note: Size 2-1/2" to 6" only.

SIZE	DIMENSIONS																		
			A		B		C		D		E								
	in	mm	150 lb.	300 lb.	150 lb.	300 lb.	150 lb.	300 lb.	150 lb. & 300 lb.	150 lb.	300 lb.								
1-1/2	40	6.5	165.1	7.50	190.5	4.88	123.95	4.96	125.98	10.02	254.51	10.02	254.51	2.00	50.8	4.45	113.03	4.53	115.06
2	50	7.0	177.8	8.50	215.9	5.20	132.08	5.30	134.62	10.02	254.51	10.02	254.51	2.00	50.8	4.45	113.03	4.53	115.06
*2-1/2	65	7.5	190.5	N/A	6.12	155.45	N/A	15.94	404.88	N/A	2.50	63.5	5.51	139.95	N/A				
3	80	8.0	203.2	11.12	284.5	6.81	172.97	6.23	158.24	15.94	404.88	15.94	404.88	3.00	76.2	6.20	157.48	6.20	157.48
4	100	9.0	228.6	12.00	304.8	7.72	196.09	7.31	185.67	18.11	459.99	18.11	459.99	4.00	101.6	7.16	181.86	7.16	181.86
6	150	15.5	393.7	15.88	403.4	9.88	250.95	9.55	242.57	24.02	610.11	24.61	625.09	6.00	152.4	9.35	237.49	9.35	237.49
*8	200	18.0	457.2	N/A	N/A	N/A	N/A	N/A	N/A	8.00	203.2	13.33	338.58	N/A					

SIZE	DIMENSIONS														ISO PATTERN			
			F		G		H		J		K							
	in	mm	150 lb.	300 lb.	150 lb. & 300 lb.	150 lb.	300 lb.	150 lb.	300 lb.	150 lb.	300 lb.	150 lb. & 300 lb.	150 lb.	300 lb.				
1-1/2	40	3.35	85.09	3.43	87.12	0.77	19.56	0.55	13.97	0.55	13.97	0.71	18.03	0.71	18.03	2.76	70.0	F07
2	50	3.64	92.46	3.72	94.49	0.77	19.56	0.55	13.97	0.55	13.97	0.71	18.03	0.71	18.03	2.76	70.0	F07
*2-1/2	65	4.59	116.59	N/A	0.87	22.10	0.67	17.02	N/A	0.87	22.10	N/A	2.76	70.0	F07			F07
3	80	5.28	134.11	5.28	134.11	0.87	22.10	0.67	17.02	0.67	17.02	0.87	22.10	0.87	22.10	2.76	70.0	F07
4	100	6.18	156.97	6.18	156.97	0.91	23.11	0.67	17.02	0.87	22.10	1.03	26.16	1.11	28.19	4.02	102.0	F10
6	150	7.80	198.12	7.80	198.12	1.50	38.10	0.91	23.11	1.06	26.92	1.37	34.80	1.43	36.32	4.02 & 4.92	102.0 & 125.0	F10 & F12
8	200	10.45	265.43	N/A	2.87	72.90	N/A	N/A	N/A	N/A	N/A	N/A	N/A	5.51	140			F14

*2-1/2" & 8" only offered in 150lb Class.

Certified dimensional drawings are available upon request.

*This table reflects only the nearest metric equivalents.

WEIGHTS

Size	1-1/2"	2"	2-1/2"	3"	4"	6"	8"
150	lbs	15.4	21.8	37.0	47.1	83.6	178.9
	kgs	7.0	9.9	16.8	21.4	37.9	81.1
300	lbs	25.5	32.0	N/A	74.0	122.7	262.0
	kgs	11.6	14.5	N/A	33.6	55.7	118.8

MAX TORQUES (in/lb)

Size	1-1/2"	2"	2-1/2"	3"	4"	6"	8"
150 lb	300	400	600	1000	2000	3800	8000
300 lb	300	400	N/A	1000	2000	3800	N/A

FLOW COEFFICIENTS

Size	C _v
1-1/2"	285
2"	500
2-1/2"	550
3"	1300
4"	2500
6"	5250
8"	10400

PRESSURE vs. TEMPERATURE CHART

